

**FRENI ELETTROMAGNETICI
MONODISCO
Serie DFM-2**

**SINGLE PLATE
ELECTROMAGNETIC BRAKES
Model DFM-2**

PRESTAZIONI (24 VCC) • PERFORMANCES (24VDC)

tipo size	coppia torque (Nm)	potenza power (W)	giri/min rpm	tempo inserzione engagement time (ms)	tempo disinserzione disengagement time (ms)	peso weight (kg)
DFM 039-2	0,6	6	10.000	15	3	0,07
DFM 045-2	0,9	6	10.000	20	4	0,11
DFM 054-2	1,8	8	10.000	25	5	0,18
DFM 065-2	3,6	10	10.000	35	6	0,28
DFM 080-2	7,5	11,5	8.000	35	10	0,32
DFM 100-2	15	16	6.000	40	20	0,59
DFM 125-2	30	21	5.000	60	30	1,11
DFM 150-2	60	21	4.000	80	45	2
DFM 190-2	120	38	3.000	100	60	3,5
DFM 230-2	240	45	3.000	115	70	7,1
DFM 290-2	480	70	2.000	130	80	12,7

DIMENSIONI (mm) • DIMENSIONS (mm)

tipo - size	A	B	C H8	D h8	E	F	G	H	I	L	N	Q	R	S	V max
DFM 039-2	31	16	11	39	4x3,4	1,5	33,5	3,5	1xM3	26,35	-	13	8	0,1	8
DFM 045-2	34	19	13	45	4x3,4	2	38	4	1xM3	31,55	-	15	10	0,1	8
DFM 054-2	43	22,3	19	54	4x3,4	2	47	5	1xM3	37,4	-	17	12	0,2	10
DFM 065-2	54	23,5	26	65	4x3,4	2	58	5	1xM4	38,7	-	24	12	0,2	15
DFM 080-2	63	18	35	80	4x4,5	2	72	5	1xM4	37	3,5	33	15	0,2	17
DFM 100-2	80	20	42	100	4x5,5	2,5	90	6	1xM4	44,5	4,3	32	20	0,2	22
DFM 125-2	100	22	52	125	4x6,6	3	112	6	1xM5	52,9	5	42	25	0,2	30
DFM 150-2	125	24	62	150	4x6,6	3,5	137	10	1xM6	61	5,5	49	30	0,3	35
DFM 190-2	160	26	80	190	4x9	4	175	10	1xM8	73	6	65	38	0,3	45
DFM 230-2	200	30	100	230	4x9	5	215	15	2xM8	89,4	7	83	48	0,5	60
DFM 290-2	250	35	125	290	4x11	6	270	20	2xM10	102,9	8	105	55	0,5	70

DENOMINAZIONE PARTI • PARTS NAME

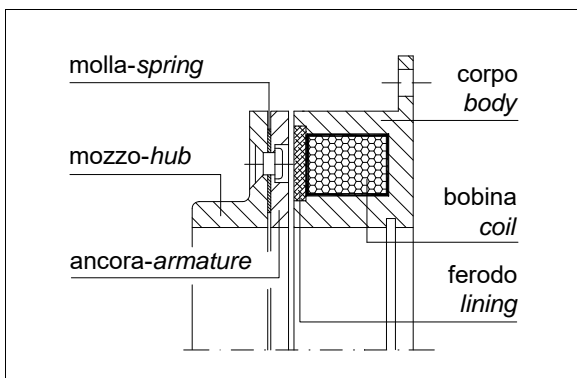

ESEMPIO DI MONTAGGIO • MOUNTING EXAMPLE

