

**FRENO A PINZA IDRAULICO  
NEGATIVO  
Tipo SYR N40**

**HYDRAULIC CALIPER  
BRAKE SPRING APPLIED  
Type SYR N40**

**PRESTAZIONI (120 bar) • PERFORMANCES (120 bar)**

tipo - size	forza F – force F (N)	Ø disco – disc Ø (mm)	coppia M - torque M (Nm)	V olio - oil V (dm <sup>3</sup> )	peso - weight (kg)
SYR N40	35.000	610 ÷ 1370	$M = F \times (\frac{\varnothing}{2} - 0,065)$	0,15	60

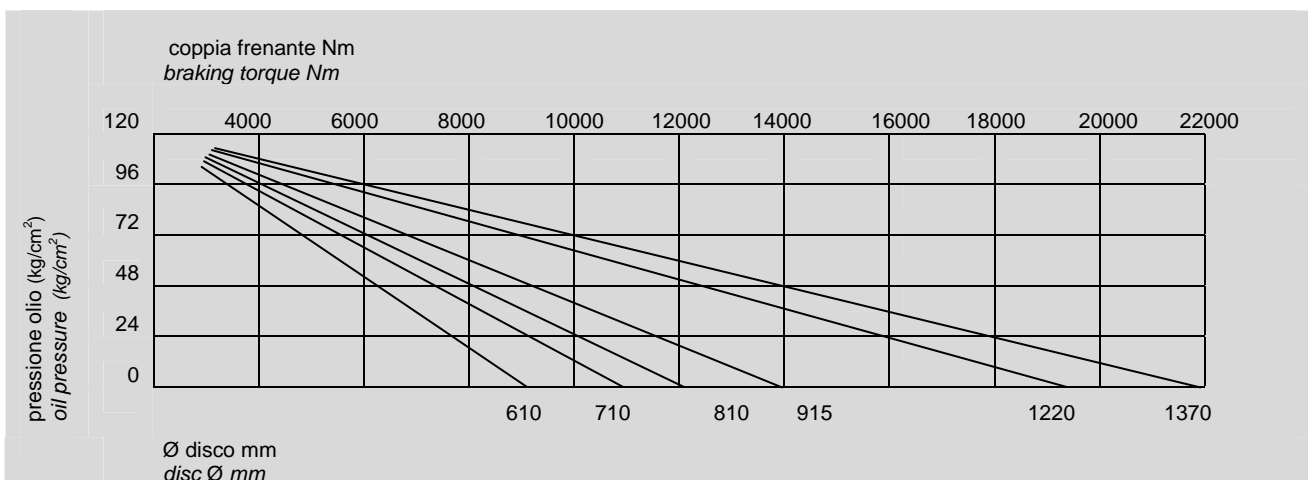

**NOME PARTICOLARI • PARTS NAME**

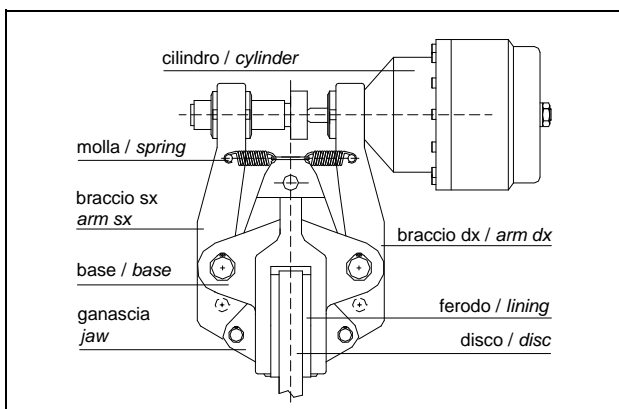

**ESEMPIO MONTAGGIO • MOUNTING EXAMPLE**

