

**FRENO A PINZA
PNEUMATICO NEGATIVO
Tipo SPP N20**

**PNEUMATIC CALIPER
BRAKE SPRING APPLIED
Type SPP N20**

PRESTAZIONI (5 bar) • PERFORMANCES (5 bar)

tipo - size	forza F – force F (N)	Ø disco – disc Ø (mm)	coppia M- torque M (Nm)	V aria - air V (dm ³)	peso - weight (kg)
SPP N20	2600	200 ÷ 610	$M = F \times (\text{Ø} / 2 - 0,032)$	0,3	9,2

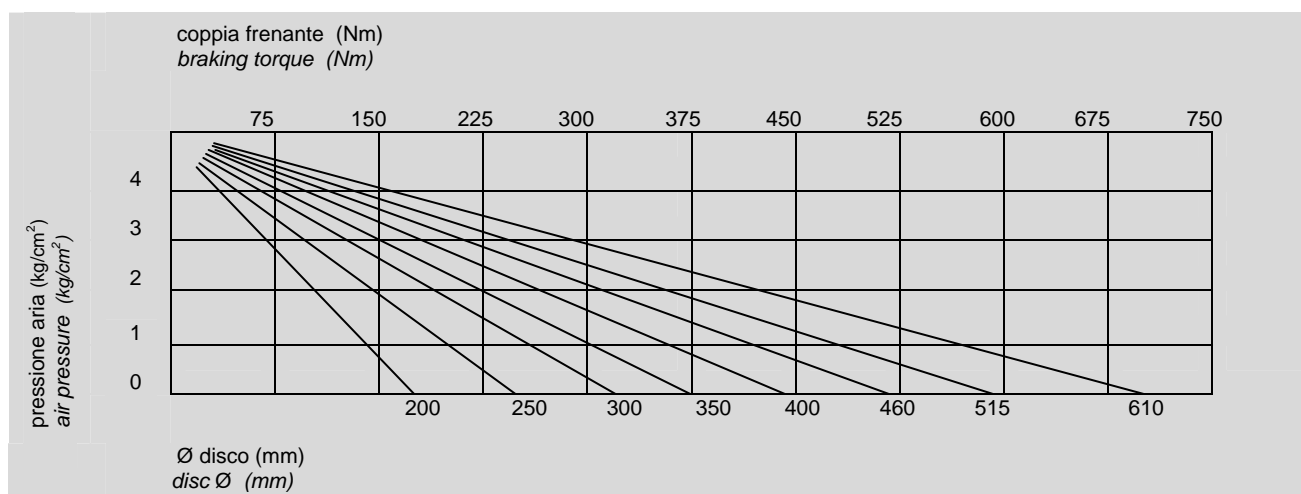

NOME PARTICOLARI • PARTS NAME

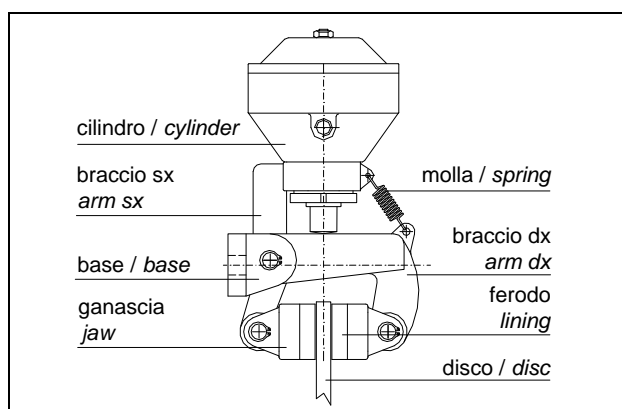

ESEMPIO MONTAGGIO • MOUNTING EXAMPLE

