

**FRENO A PINZA  
PNEUMATICO POSITIVO  
Tipo SPP 020**

**PNEUMATIC CALIPER  
BRAKE  
Type SPP 020**

**PRESTAZIONI (7bar) • PERFORMANCES (7 bar)**

tipo - size	forza F – force F (N)	Ø disco – disc Ø (mm)	coppia M – torque M (Nm)	V aria - air V (dm <sup>3</sup> )	peso - weight (kg)
SPP 020	3500	200 ÷ 610	$M = F \times (\frac{\text{Ø}}{2} - 0,032)$	0,25	7,5

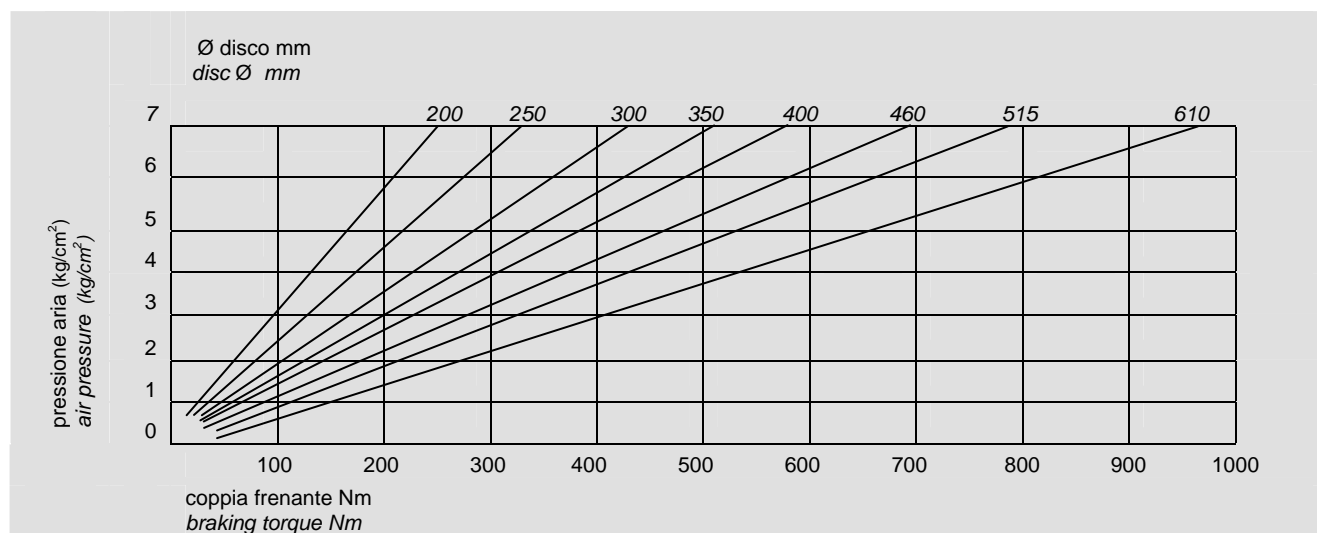

**NOME PARTICOLARI • PARTS NAME**

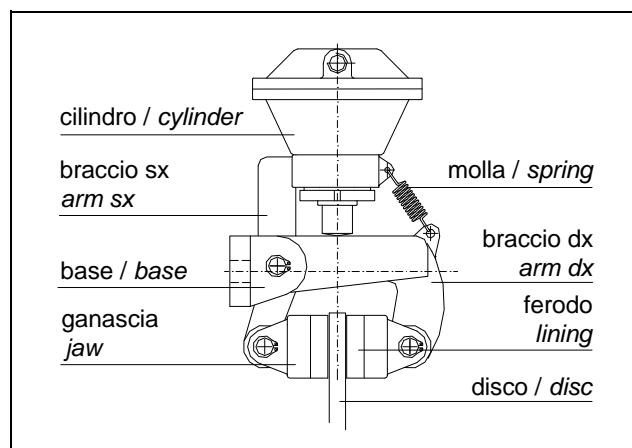

**ESEMPIO MONTAGGIO • MOUNTING EXAMPLE**

