

**FRENI IDRAULICI LAMELLARI
CON TRASCINAMENTO
INTERNO
Serie FCI**

**MULTI PLATE HYDRAULIC
BRAKES WITH INTERNAL
DRIVING
Model FCI**

PRESTAZIONI (8 bar) • PERFORMANCES (8 bar)

tipo size	coppia – torque (Nm)		g/min - rpm max	Vol aria - air Vol (cm ³)	lamelle – plates int/ext	mozzo hub	peso - weight (Kg)
	M dyn	M stat					
FCI 106	50	90	3500	7	5/4	MZI 106	2.3
FCI 120	90	160	3200	9	5/4	MZI 120	3.3
FCI 145	160	300	2800	15	5/4	MZI 145	6

DIMENSIONI (mm) • DIMENSIONS (mm)

tipo size	A	B h11	C	D h6	E	F	G	H	J	K	L	M	N	T	alette lugs nr
FCI 106	64	106	48	88	55	25	13	1/8"	6	3.5	20	36	9	19	3
FCI 120	69	118	56	110	66	28	16	1/8"	8	4	25	38	12	24,5	3
FCI 145	86	146	70	136	86	38	25	1/8"	10	5	35	52	14	30,5	3

NOME PARTICOLARI • PARTS NAME

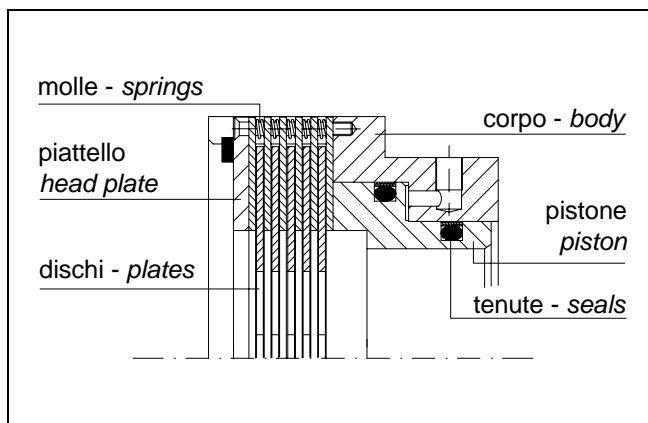

ESEMPIO MONTAGGIO • MOUNTING EXAMPLE

