

**FRIZIONI ELETTRICHE
MONODISCO CON ANELLO
COLLETORE
Serie EMC**

**SINGLE PLATE
ELECTROMAGNETIC CLUTCHES
WITH SLIP RING
Model EMC**

PRESTAZIONI (24 VCC) • PERFORMANCES (24VDC)

tipo size	Coppia-torque (Nm)		tempo - time(ms)		potenza - power (W)		peso - weight Kg
	M _d	M _s	inserzione engagement	disinserzione disengagement	20°	120°	
EMC 145	40	70	170	55	38	27	3,5
EMC 170	60	100	200	65	38	27	4,3
EMC 210	100	160	260	70	45	33	8
EMC 255	200	320	300	80	50	36	10,2
EMC 310	400	640	380	85	60	42	18,5
EMC 390	600	950	460	95	60	42	28

- per inserzioni in movimento riferirsi ai valori di coppia dinamica M_d - for engagement in motion refer to dynamic torque M_d
 - per inserzioni da fermo o per frizione già inserita riferirsi ai valori di coppia statica M_s - for stationary or for engaged clutches refer to static torque M_s.

DIMENSIONI (mm) • DIMENSIONS (mm)

tipo size	A	B	C max	D	E	F max	G	J	L	P	Q	R	S	T
EMC 145	76	148	30	130	47	0,6	63	18	44	6	10	67	3xM8	3x8
EMC 170	78	168	30	130	58	0,6	63	18	44	6	10	77	3xM8	3x8
EMC 210	86,5	210	40	198	64	0,8	70	20	45	9	15,5	90,5	3xM12	3x12,7
EMC 255	93	255	60	198	105	1	76,5	20	45	9	15,5	133,54	3xM12	3x12,7
EMC 310	113,5	312	75	198	118	1	95	23,5	75	9	15,5	149,22	4xM12	4x12,7
EMC 390	120,5	390	75	198	181	1,2	102	22,5	75	9	15,5	215,90	4xM12	4x12,7

DENOMINAZIONE PARTI • PARTS NAME

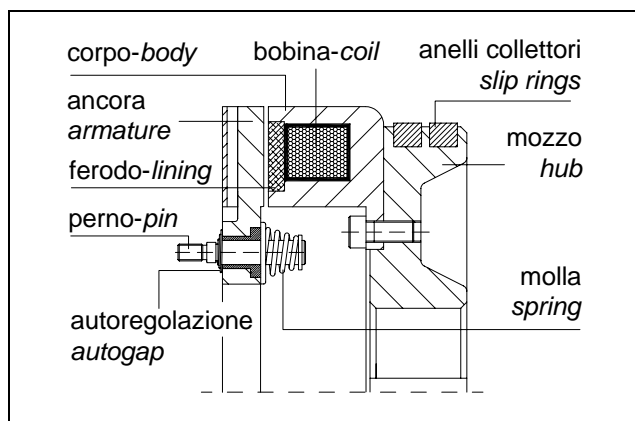

ESEMPIO MONTAGGIO • MOUNTING EXAMPLE

