

CAMPANE PER LIMITATORI
GSA
Serie CAL

HOUSINGS FOR LIMITERS
GSA
Model CAL

DIMENSIONI (mm) • DIMENSIONS (mm)

tipo - size	A h11	B H11	C H7	D	E	F	nr x G
CAL 050	68	57,5	30	26	22	18	3 x 12
CAL 069	80	70,5	40	36	30	22	3 x 12
CAL 078	90	78,6	45	38	32	26	3 x 12
CAL 093	112	98,5	45	38	32	26	3 x 15
CAL 108	116	105,8	50	42	34	28	6 x 15
CAL 130	145	131	60	48	40	34	6 x 20,2
CAL 163	179	164	70	60	50	42	9 x 20,2

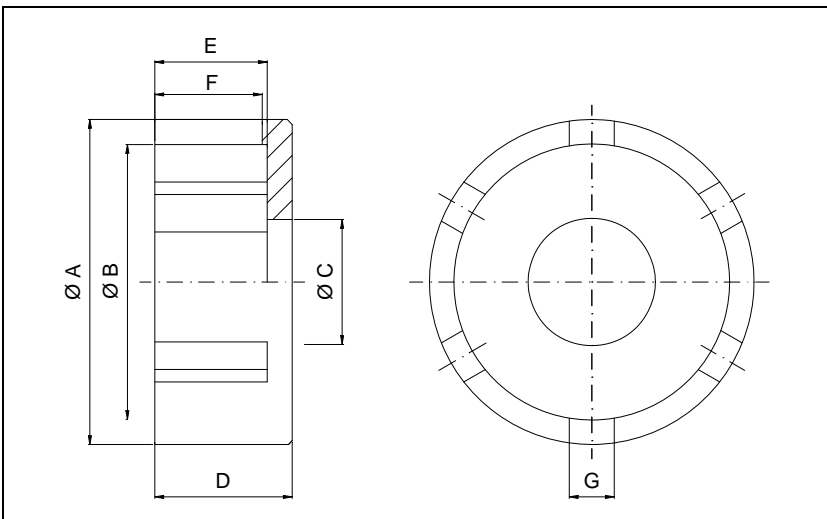

CAMPANE PER FRIZIONI
MECCANICHE FSA - FDA
Serie CAM

HOUSINGS FOR MECHANICAL
CLUTCHES FSA - FDA
Model CAM

DIMENSIONI (mm) • DIMENSIONS (mm)

tipo - size	A	B	C H7	D	E	F	G
CAM 069	80	69,5	30	36	30	22	3 x 12,5
CAM 078	90	78,5	40	38	32	25	3 x 12,5
CAM 086	98	87	45	40	34	26	6 x 12,5
CAM 098	110	98,5	50	42	34	26	8 x 12,5
CAM 108	122	109	50	42	34	26	8 x 16
CAM 130	148	131	60	50	44	34	8 x 16